

REV.	ECN NO.	LOCAS.	DESCRIPTION	DATE	DESIGN
AO			RELEASE TO CUSTOMER		HANG

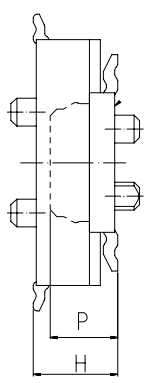
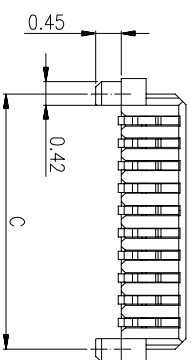
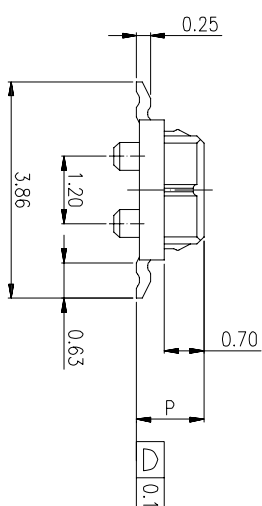
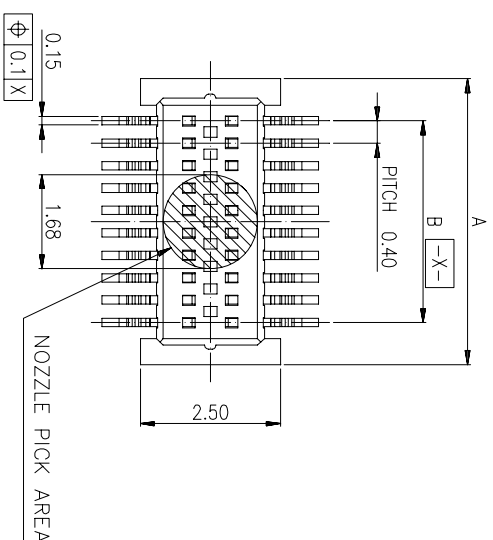

MATING SECTION

MATING HEIGHT

MALE	FEMALE
DIM. P	DIM. H
1.20	1.5mm
1.70	2.0mm

16.5	15.6	17.1	80
14.5	13.6	15.1	70
12.5	11.6	13.1	60
11.3	10.4	11.9	54
10.5	9.6	11.1	50
8.5	7.6	9.1	40
7.3	6.4	7.9	34
6.9	6.0	7.5	32
6.5	5.6	7.1	30
5.7	4.8	6.3	26
5.3	4.4	5.9	24
4.9	4.0	5.5	22
4.5	3.6	5.1	20
3.7	2.8	4.3	16
2.5	1.6	3.1	10
C	B	A	PIN.

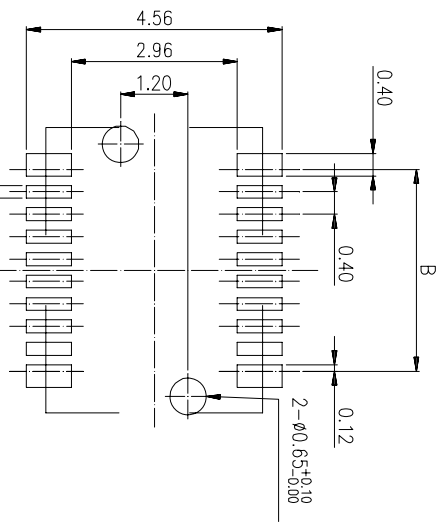

RECOMMENDED PCB PATTERN LAYOUT

DIM	TOL	DIM	TOL
X.	±0.30	X.	±4.0°
X.X	±0.25	X.X.	±3.0°
X.XX	±0.20	X.XX.	±2.0°
X.XXX	±0.10	X.XXX.	±1.0°

LASTAR

Lastar Technology CO., LTD

DRAW NO.	041-XX1-30L2	DATE	110205
DESIGN	HANG	110205	
CHECK	WANGCM	110205	
APPROVED	HUYX	110205	

DRAW NAME:	BOARD TO BOARD PLUG Pitch0.4mm 30Pin
P/N NO.	BTB-041-XX1-30L2-10
UNIT:	mm
SHEET:	N/A
MODEL:	
REV.	AO
SCALE	N/A

- NOTES:
- MATERIAL:
 - HOUSING :THERMOPLASTIC UL 94 V-0.
 - CONTACTS :COPPER ALLOY
 - FINISH CONTACT:
 - CONTACT AREA PLATING:HARD GOLD
 - BASE PLATING:NICKEL THICKNESS AT 50μ" MIN

THIS DRAWING CONTAINS INFORMATION THAT IS PROVIDED BY LASTAR TECHNOLOGY AND SHOULD NOT BE USED WITHOUT WRITTEN PERMISSION